

FLGC/SLGC SERIES

Sight Level Gauges



**FILTRATION
PRODUCTS
CORP.**

(763) 428-6415

Fax: (763) 428-8659
18151 Territorial Road
Dayton, MN 55369
www.filtrationproducts.com



FEATURES

Available In Both Metric And SAE Threads

O-Ring Type Construction

3 Sizes: 3", 5" And 10" Between Bolt Centers

For Non-Pressurized Tanks Only

Can Be Mounted On Tapped Holes

Suitable For Mineral Or Petroleum Based Fluids

Contains Polycarbonate Components - Not Compatible
With Acetone, Ammonia Based Cleaners or Brake Fluid

Thermometer Standard

Limit Bolt Torque to 3 Ft Lbs [36 In Lbs]

Maximum Operating Temperature: 176° F [80° F]

Blue Thermometer Fluid for Enhanced Visibility

FLGC/SLGC SERIES

Sight Level Gauges

DIMENSIONS



FLGC5T



FLGC3T

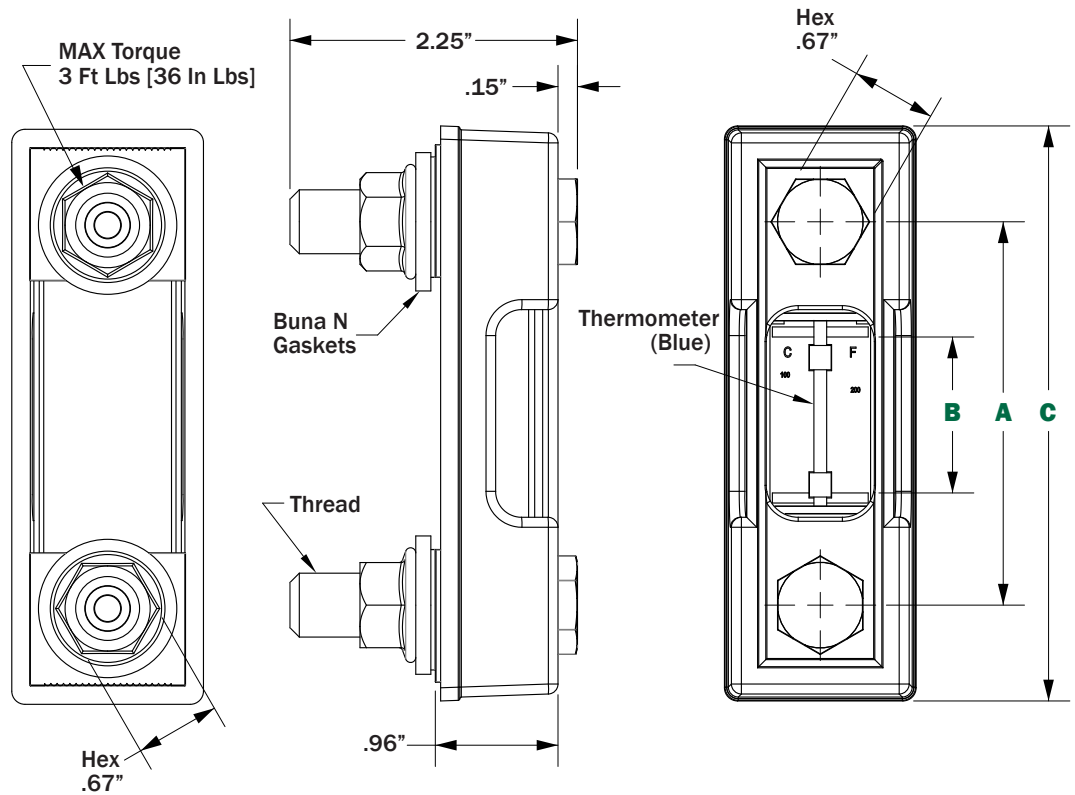

SPECIFICATIONS

MODEL	DIMENSIONS		
	A	B	C
FLGC3T	3.00"	1.26"	4.50"
FLGC5T	5.00"	2.99"	6.50"
FLGC10T	10.00"	7.87"	11.38"
SLGC3T	3.00"	1.26"	4.50"
SLGC5T	5.00"	2.99"	6.50"
SLGC10T	10.00"	7.87"	11.38"

ORDERING CODE

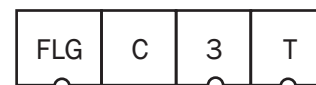

THREAD

FLG · M12 - 1.75
SLG · 1/2" - 12

THERMOMETER

OMIT · NO
T · YES

LENGTH

3 · 3" Pattern
5 · 5" Pattern
10 · 10" Pattern