

SC · SE · ST SERIES

Strainers Internal Mounted

SC Series · Die Cast Aluminum Nut Cap
SE Series · Nylon Nut Cap
ST Series · Steel Nut Cap



FEATURES

Used in fluid reservoirs or sumps.

Flows to 100 GPM (378 LPM).

1/2" to 3" NPT.

Stainless steel pleated media. 100 mesh standard.
30, 60 or 200 mesh optional.

Temperature to 212° F (100° C)

Optional 3 PSI by-pass.

Compatible with petroleum and mineral based fluids.

SC · SE · ST SERIES

Strainers Internal Mounted



ST



SE



SC

ORDERING CODE

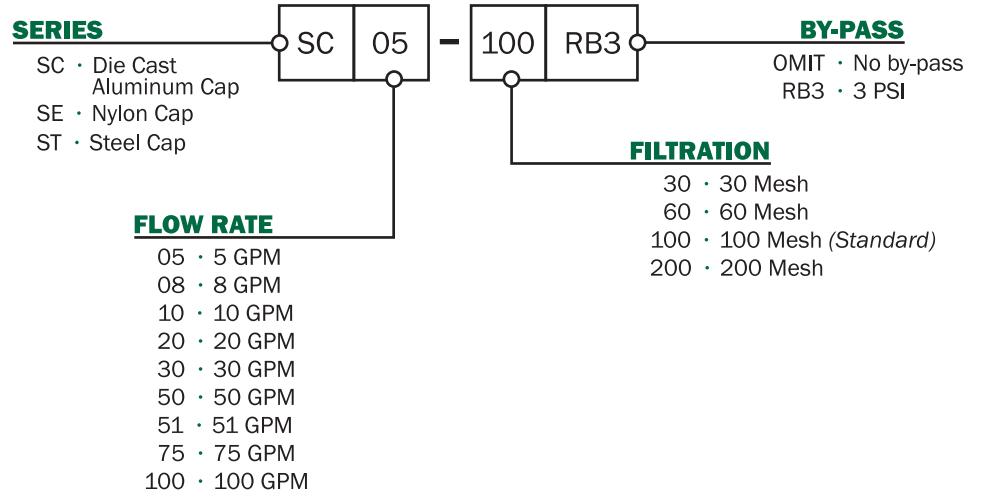

FLOW RATE

SC	SE	ST	GPM	For SE/ST Only At 225 SSU oil @ 100° F through 100 mesh element.	
				FLOW VELOCITY @ Rated Flow (Ft./Sec.)	GPM @ 5 Ft./Sec. Flow Velocity
SC05	SE05	ST05	5	5.28	4.7
SC08	SE08	ST08	8	4.81	8.3
SC10	SE10	ST10	10	3.71	13.5
SC20	SE20	ST20	20	4.29	23.3
SC30	SE30	ST30	30	4.73	31.7
SC50	SE50	ST50	50	7.88	50
SC51	SE51	ST51	50	4.78	52.2
SC75	SE75	ST75	75	5.02	74.7
SC100	SE100	ST100	100	4.34	114.8

DIMENSIONS

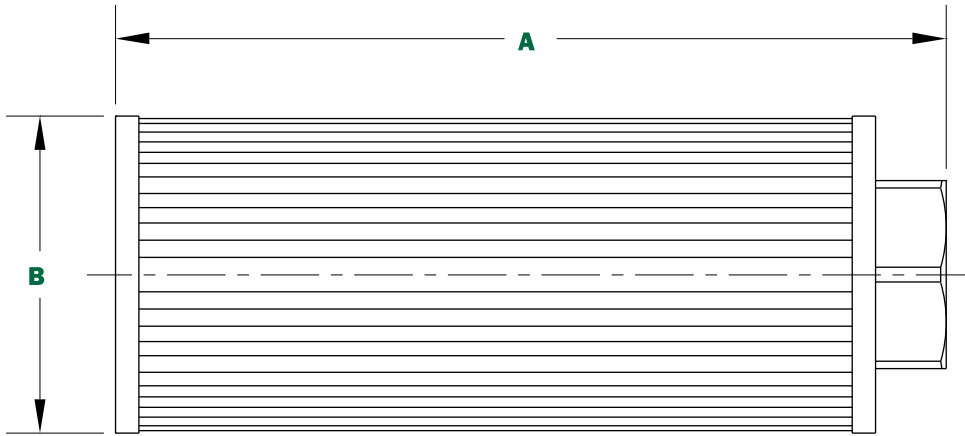

SE / ST SPECIFICATIONS

MODEL NUMBER	SIZE (NPT)	GPM	SCREEN AREA (Sq. In.)	DIMENSIONS		WEIGHT (lbs)
				A	B	
ST05	1/2"	5	62	3.1"	2.6"	.5
SE08 / ST08	3/4"	8	68	3.5"	2.6"	.5
SE10 / ST10	1"	10	110	5.4"	2.6"	.7
SE20 / ST20	1-1/4"	20	162	6.9"	3.4"	1.0
SE30 / ST30	1-1/2"	30	225	8.1"	3.4"	1.2
SE50 / ST50	1-1/2"	50	340	10.0"	3.9"	1.4
SE51 / ST51	2"	50	340	10.0"	3.9"	1.8
SE75 / ST75	2-1/2"	75	400	10.1"	5.1"	2.3
SE100 / ST100	3"	100	500	11.8"	5.1"	3.0

SC SPECIFICATIONS

MODEL NUMBER	SIZE (NPT)	GPM	SCREEN AREA (Sq. In.)	DIMENSIONS		WEIGHT (lbs)
				A	B	
SC05-100	1/2"	5	35	4.1"	1.8"	.4
SC08-100	3/4"	8	63	4.3"	2.5"	.5
SC10-100	1"	10	84	5.5"	2.5"	.5
SC20-100	1-1/4"	20	144	5.5"	3.4"	.7
SC30-100	1-1/2"	30	180	6.6"	3.4"	1.0
SC50-100	1-1/2"	50	216	7.9"	3.4"	1.2
SC51-100	2"	50	315	10.2"	3.9"	1.8
SC75-100	2-1/2"	75	432	8.3"	5.9"	2.3
SC100-100	3"	100	570	10.7"	5.9"	3.0